

Datasheet

UltraLift E



At A Glance

- ✓ 3:1 WLL - safely lift ferrous material
- ✓ Lifts up to 2000kg (4400lb) Flat Plate
- ✓ Lifts up to 900kg (1980lb) Round Bar
- ✓ Lever to manually Switch 'On' and 'Off'
- ✓ Switch has Locking Safety Mechanism

Our UltraLift E lifter range is a performance lifter for safely lifting ferrous plate and round bar, with a 3:1 WLL design and a Locking Safety Mechanism for the manual lever to make the lift safer.

The performance of these units is always application specific. Never exceed the WLL (Working Load Limit) - formerly the SWL (Safe Working Load). The Safety Factor for lifting is 3:1 for this range. Always use LOLER, PUWER, ASME B30.20 and H&S advice.

The UltraLift E range is used to lift ferrous sheets and ferrous round bar. Depending on the version, the UltraLift E can be used on minimum ferrous plate thickness from 15mm thick (bearing in mind that the thinner the plate the less the holding force achieved will be). For safely lifting thinner plate and sheet, please use the UltraLift TP range. The WLL varies from up to 100kg (220lb) for the ULE0100 rising to up to 2000kg (4400lb) for the ULE2000 when used on ferrous flat plate. The WLL varies from up to 50kg (110lb) for the ULE0100 (80mm maximum diameter) rising to up to 900kg (1980lb) for the ULE2000 when used on ferrous round bar (diameter limits apply for each version). Please note that the WLL varies with material type, thickness/diameter, air gap and contact area. These figures are based on lifting high quality mild steel of the stated sheet thickness or diameter with no air gap in the way (see table on next page for further details). Lifting Performance achieved is always application specific.

Maintain Health & Safety at all times. Perform a small safety lift first. Lifting performance could vary depending on the application. Performance will vary with air gap, steel shape (steel thickness and/or diameter), steel type (permeability), surface finish and temperature. Lift loads vertically with load not unbalanced, avoiding any sudden movements. Thinner and wider materials may bend/flex risking peel and lift failure - use spreader beams for wider loads and for loads that bend/flex. Do not use any lifter if it appears to be damaged. Inspect the lifter at least annually. We can inspect and service/repair our Lifters for you.

Benefits

- No Power Supply required
- 3:1 Safety Factor for lifting
- Lifts Ferrous Plate up to 2000kg (4400lb) WLL
- Lifts Ferrous Round Bar up to 900kg (1980lb) WLL
- Locking switch handle safety mechanism

Performance

Magnetic Performance	Up to 2000kg (4400lb) WLL (value varies with thickness and/or diameter) - see next page
Magnet Type	Permanent Magnet Lifter
Temperature Range	-10°C to +40°C (14°F to +104°F)

Suitability

Suitable Products	Ferrous materials (e.g. mild steel)
Suitable Location	Example - factory shopfloor / production line

Materials

Magnetic Material	Proprietary Permanent Magnet grade material
Other Parts	Various, including Mild Steel, Aluminium, Plastic

Maintenance

- As part of LOLER, PUWER, ASME B30.20 and H&S advice, you need to regularly inspect Lifters to ensure they are not damaged and are suitable for lifting the parts
- Annual inspection is a minimum requirement
- We can inspect and service / repair our Lifters for you

Alternatives

- UltraLift+ (maximum safety lifting) for thicker ferrous plate and round bar
- UltraLift LM for thicker ferrous plate & round bar (with 90° lift frame variant)
- UltraLift TP for thinner ferrous plate

Lifting Range



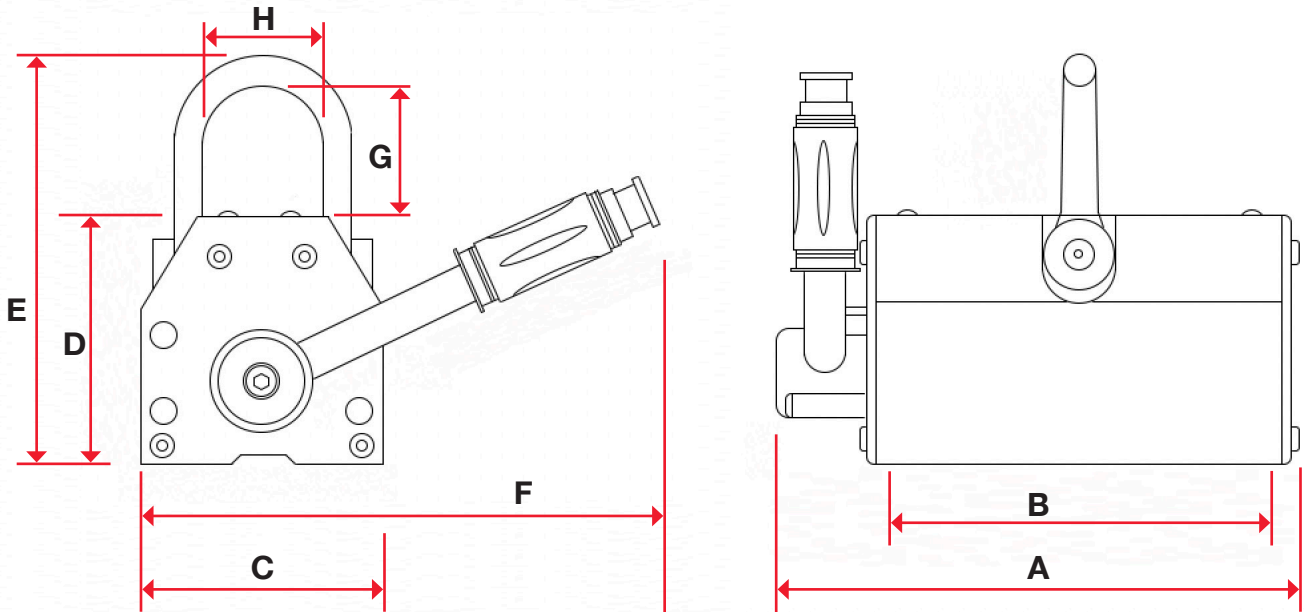

Product Number	Dimensions (mm)								Self Weight (kg)	Flat Plate/Section WLL* (kg)	Flat Plate/Section Minimum Thickness (mm)	Maximum Material Length (mm)	Round Bar WLL* (kg)	Round Bar Maximum Diameter (mm)	Units per Pack
	A	B	C	D	E	F	G	H							
ULE0100	131	88	65	73	124	175	45	32	3	100	15	1000	50	80	1
ULE0300	202	157	95	95	169	253	63	46	10	300	20	1500	150	100	1
ULE0600	295	240	120	118	220	285	90	61	23	600	30	2000	300	140	1
ULE1000	355	300	134	140	269	315	115	73	39	1000	40	2500	500	180	1
ULE2000	442	378	162	170	310	410	120	91.5	74	2000	50	3000	900	300	1

* Please note that the Working Load Limit (WLL) is now used instead of Safe Working Load (SWL). The Lifting force values shown include the 3:1 safety factor and have been based on using thick high magnetic permeability steel with no air gaps. Air gaps, thinner materials and materials with lower magnetic permeability can all reduce the pull force a lifter can actually achieve. Please note that the achievable pull force is reduced when lifting thinner mild steel plate. Please note that the diameter of the round bar can affect the amount of lift that can be achieved. You must follow LOLER, PUWER, ASME B30.20 and H&S advice. You should always check for a downrate, factor in any downrate to then perform a safety lift, then perform a full lift only after a successful safety lift.

For further assistance, please contact sales@eclipsemagnetics.com

Although we have made every attempt to provide accurate information, we do reserve the right to change any of the information in this document without notice.

We cannot accept any responsibility or liability for any errors or problems caused by using any of the information provided.

Conversions Guide:-

1kg ≈ 2.204lb ≈ 9.806N

1lb ≈ 0.453kg ≈ 4.448N

1N ≈ 0.101kg ≈ 0.224lb

10mm ≈ 0.393in (≈ 25/64in)

1in ≈ 25.4mm

(the above conversion values are rounded down)